

# LifeTrail Station 7 (ADA) LAWS-7R

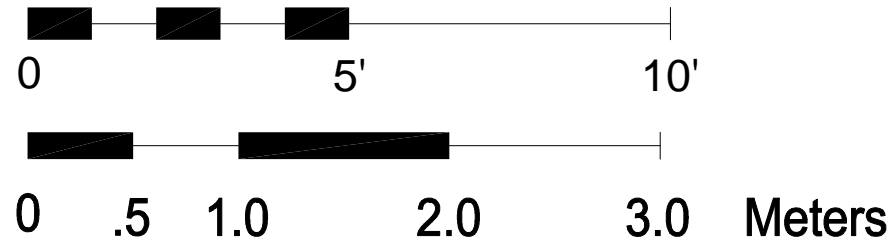

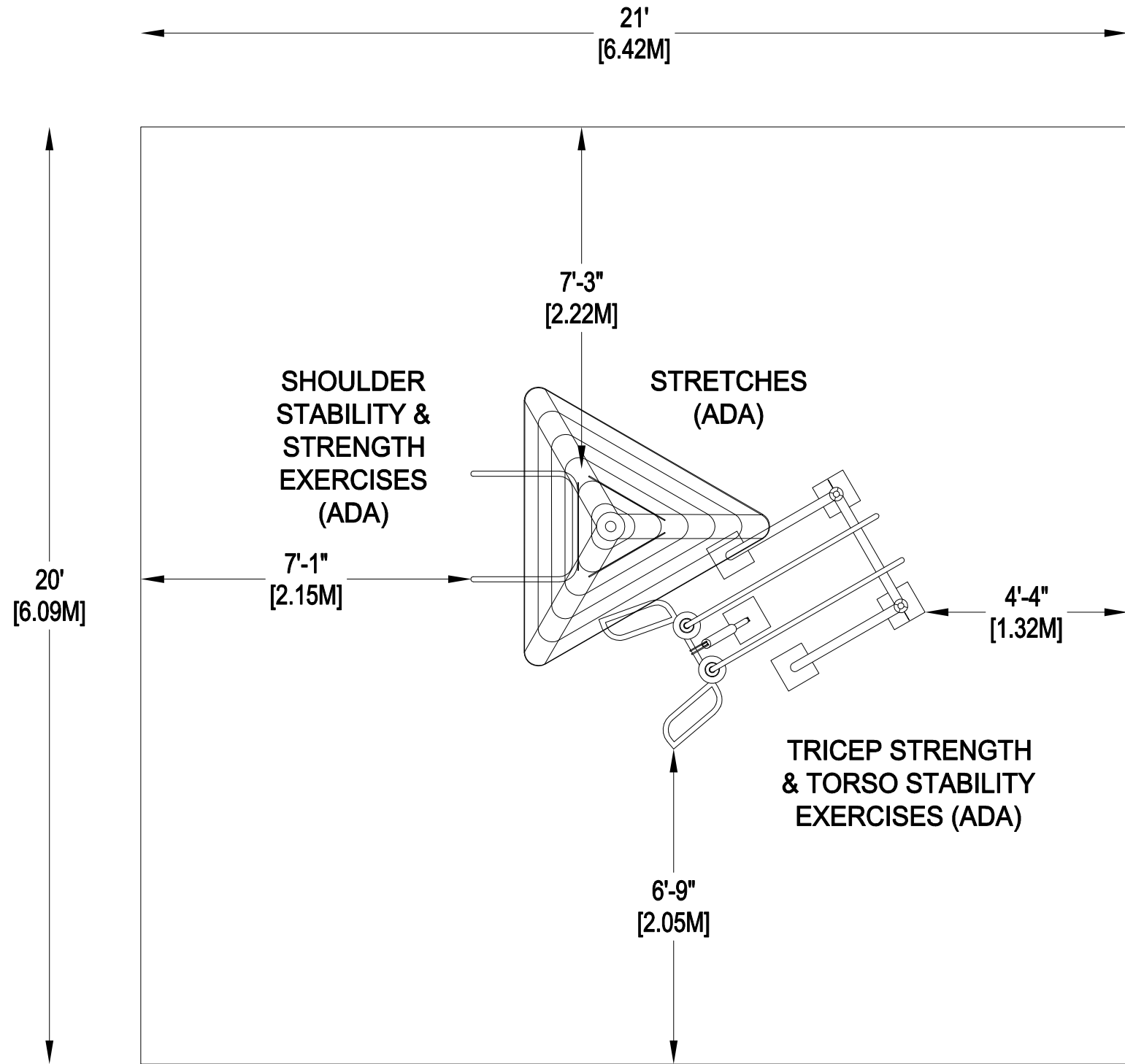







\*Playground Supervision Required

**PLAYWORLD**<sup>TM</sup>

© 2007 Playworld Systems, Inc.  
Playworld™ is a brand of Playworld Systems, Inc.

PROJECT NO: <b>LAWS-7R</b>	REV: -	DATE: <b>4-FEB-2014</b>
SYSTEM: <b>LIFETRAIL</b>	SCALE: <b>NOT TO SCALE</b>	
SITE PLAN		DRAWN BY: <b>R. DIEFFENBACH</b>

Playworld Systems, Inc.  
1000 Buffalo Road  
Lewisburg, PA  
17837-9795 USA

 3 USERS	 NA Ft.
 50+	 420 Sq.Ft.
 98" x 79" x 92"	 21' x 20'

# LAWS-7R

LIFETRAIL ADVANCED WELLNESS SYSTEM



# LAWS-7R

Design Number: LAWS-7R - Bill Of Material

<b>Ref. No.</b>	<b>Part No.</b>	<b>Description</b>	<b>Quantity</b>
<b>LifeTrail Frame</b>			
1	ZZLT0045	LIFETRAIL FRAME W/ ROOF	1
<b>LifeTrail Activity</b>			
2	ZZLT0058	LIFETRAIL OVERHEAD PRESS (REG & ADA)	1
<b>LifeTrail WheelChair Activity</b>			
3	ZZLT0060	LIFETRAIL SHOULDER STABILTY & STRENGTH EXERCISES ADA	1
4	ZZLT0064	LIFETRAIL STRETCHES (ADA)	1
<b>LifeTrail Kits</b>			
5	ZZLT0068	LIFETRAIL TOOL AND ADDITIONAL PARTS KIT W/AEROSOL	1
6	ZZLTGUID	LIFETRAIL GUIDELINES	1
7	ZZUN9966	LIFETRAIL MAINTENANCE KIT w/ AEROSOL	1



# LAWS-7R

Post/Installation: Steel-Footed

Design Number: LAWS-7R - Pricing Schedule  
2014 Pricing

Ref. No.	Part No.	Qty.	Description	Unit Weight (lbs)	Unit List (US\$)	Total Weight (lbs)	Total List (US\$)
<b>Modular Playscape:</b>							
<b>LifeTrail Frame</b>							
1	ZZLT0045	1	LIFETRAIL FRAME W/ ROOF	226	1,442.00	226.00	1,442.00
<b>LifeTrail Activity</b>							
2	ZZLT0058	1	LIFETRAIL OVERHEAD PRESS (REG & ADA)	283.6	2,952.00	283.60	2,952.00
<b>LifeTrail WheelChair Activity</b>							
3	ZZLT0060	1	LIFETRAIL SHOULDER STABILTY & STRENGTH EXERCISES ADA	38.97	552.00	38.97	552.00
4	ZZLT0064	1	LIFETRAIL STRETCHES (ADA)	21.07	422.00	21.07	422.00
<b>LifeTrail Kits</b>							
5	ZZLT0068	1	LIFETRAIL TOOL AND ADDITIONAL PARTS KIT W/AEROSOL	2.03	0.00	2.03	0.00
6	ZZLTGUID	1	LIFETRAIL GUIDELINES	0	0.00	0.00	0.00
7	ZZUN9966	1	LIFETRAIL MAINTENANCE KIT w/ AEROSOL	0	0.00	0.00	0.00
<b>Total:</b>						<b>571.67</b>	<b>5,368.00</b>
<b>Independent Items:</b>							
<b>Total:</b>						<b>0.00</b>	<b>0.00</b>
<b>Grand Total:</b>						<b>571.67</b>	<b>5,368.00</b>

Please Note:

1. When placing an order for this project, the drawing number is representative of the Playmakers, Challengers or Explorers playstructure only. Items listed under 'Independent Items' must be listed on your purchase order separately to be included.



# LAWS-7R

Design Number: LAWS-7R - Compliance and Technical Data

Reference Document: ASTM F1487

Ref. No.	Part No.	Qty.	Description	Unit ASTM Status	Total Weight (lbs)	Pre-Consumer Recycled Content (lbs)	Post-Consumer Content (lbs)	CO2e Footprint (kgs)	Users	Install Hours	Concrete (Yds3)	Active Play Events
1	ZZLT0045	1	LIFETRAIL FRAME W/ ROOF	N/A	226.00			617	0	2.50	0.25	0
2	ZZLT0058	1	LIFETRAIL OVERHEAD PRESS (REG & ADA)	N/A	283.60			801	1	4.00	0.40	1
3	ZZLT0060	1	LIFETRAIL SHOULDER STABILTY & STRENGTH EXERCISES ADA	N/A	38.97			235	1	0.50	0.00	1
4	ZZLT0064	1	LIFETRAIL STRETCHES (ADA)	N/A	21.07			210	1	0.50	0.00	1
5	ZZLT0068	1	LIFETRAIL TOOL AND ADDITIONAL PARTS KIT W/AEROSOL	N/A	2.03			96	0	0.00	0.00	0
6	ZZLTGUID	1	LIFETRAIL GUIDELINES	N/A	0.00			TBD	0	0.25	0.00	0
7	ZZUN9966	1	LIFETRAIL MAINTENANCE KIT w/ AEROSOL	N/A				116				
<b>Totals:</b>					<b>571.67</b>	<b>66</b>	<b>135</b>	<b>2,075</b>	<b>3</b>	<b>7.75</b>	<b>0.65</b>	<b>3</b>
					<b>257.25 Kg</b>	<b>30 Kg</b>	<b>61 Kg</b>	<b>2 Metric Tons</b>			<b>0.49 m3</b>	



# LAWS-7R

Design Number: LAWS-7R - Compliance and Technical Data

Reference Document: ASTM F1487

Ref. No.	Part No.	Qty.	Description	Unit ASTM Status	Total Weight (lbs)	Pre-Consumer Recycled Content (lbs)	Post-Consumer Content (lbs)	CO2e Footprint (kgs)	Users	Install Hours	Concrete (Yds3)	Active Play Events
----------	----------	------	-------------	------------------	--------------------	-------------------------------------	-----------------------------	----------------------	-------	---------------	-----------------	--------------------

## ASTM F1487

The lay-out for this custom playscape, design number LAWS-7R, has been configured to meet the requirements of the ASTM F1487 standard. In addition, each of the above components listed as "Certified" have been tested and are IPEMA certified. Components listed as "Not Applicable" do not fall within the scope of the ASTM F1487 standard and have not been tested. IPEMA certification can be verified on the IPEMA website, [www.ipema.org](http://www.ipema.org). In the interest of playground safety, IPEMA provides a Third Party Certification Service which validates compliance.

## 2010 ADA Standards for Accessible Design

The lay-out was also designed to meet the 2010 Standards published 15-Sep-2010, by the Department of Justice when installed over a properly maintained surfacing material that is in compliance with ASTM F1951 "Accessibility of Surface Systems Under and Around Playground Equipment" as well as ASTM F1292, "Impact Attenuation of Surfacing Materials Within the Use Zone of Playground Equipment", appropriate for the fall height of the structure.

## Installation Times

Installation times are based on one experienced installer. A crew of three experienced individuals can perform the installation within the given time, each member working 1/3 of the given hours. [Eg. Installation Time = 30 hours. For a crew of three, each member will work 10 hours on the installation for a total of 30 hours on the project.]

## Carbon Footprint

The CO2e (carbon footprint given in Kilograms and Metric Tons) listed above is a measure of the environmental impact this play structure represents from harvesting raw materials to the time it leaves our shipping dock. Playworld Systems nurtures a total corporate culture that is focused on eliminating carbon producing processes and products, reducing our use of precious raw materials, reusing materials whenever possible and recycling materials at every opportunity. Playworld Systems elected to adopt the Publicly Available Specification; PAS 2050 as published by the British Standards Institute and sponsored by Defra and the Carbon Trust. The PAS 2050 has gained international acceptance as a specification that measures the greenhouse gas emissions in services and goods throughout their entire life cycle.

## Pre-Consumer Recycle Content

A measurement, in pounds, that qualifies the amount of material that was captured as waste and diverted from landfill during an initial manufacturing process and is being redirected to a separate manufacturing process to become a different product. E.g. 100% of our Aluminum Tubing is made from captured waste material during the manufacturing process of extruded Aluminum products such as rods, flat bars and H-channels.

## Post-Consumer Recycle Content

A measurement, in pounds, that qualifies the amount of material that was once another product that has completed its lifecycle and has been diverted from a landfill as a solid waste through recycling and is now being used in a Playworld Systems' product. E.g. \*\*20% to 40% of the steel in our steel tubing and sheet steel have been diverted from landfills. Automobiles are scrapped and recyclable steel is purchased by the steel mill that produces our raw product.

\*\* The amount of Post-Consumer recycled steel fluctuates daily based on the availability of the recycled steel.

