

Simplicity

IPL-1508

Equipment Manufacturer

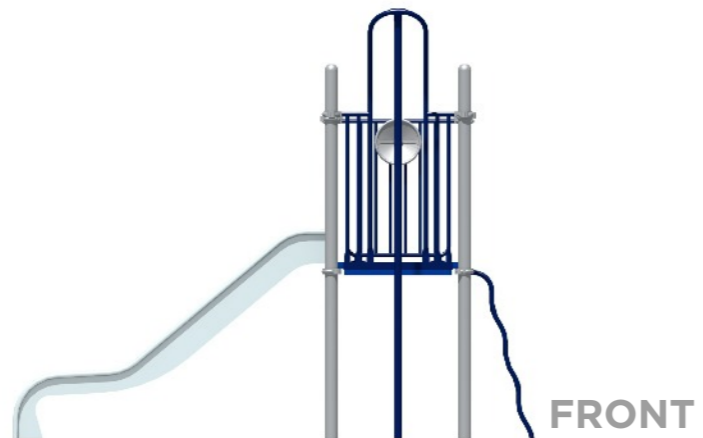



Playworld Systems, Inc.
1000 Buffalo Road
Lewisburg, PA
17837-9795 USA

EQUIPMENT SIZE:
3,58M x 1,58M x 2,96M

USE ZONE:
7,08M x 4,59M

AREA: **24,89SqM** PERIMETER: **19,91M**

FALL HEIGHT:
1,22M

USER CAPACITY: **9** AGE GROUP: **6-14**

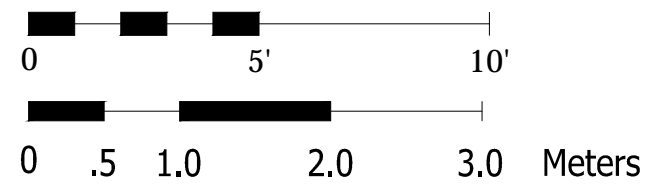
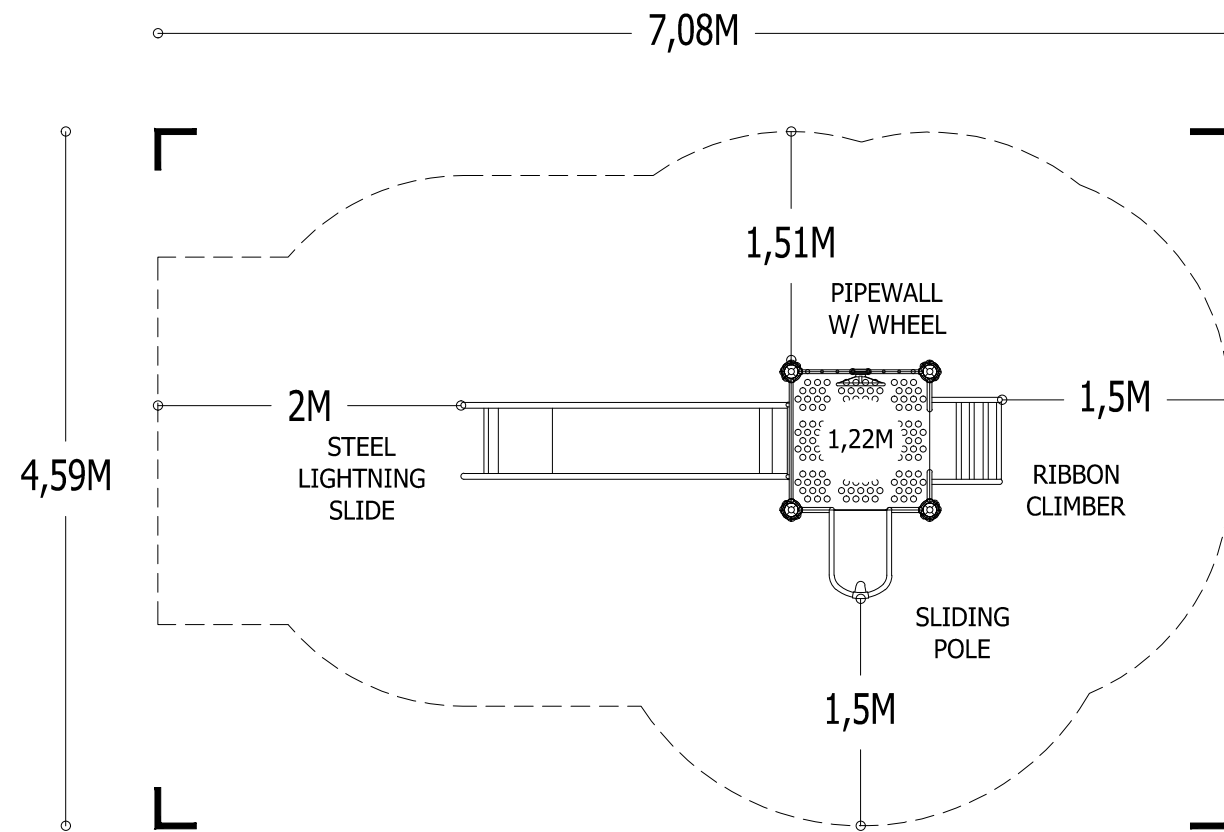

SIMPLICITY
INTERNATIONAL COLLECTION

✓ EN-1176

PROJECT NO: **IPL-1508A** SCALE: **1:50**

DRAWN BY: **J. KAZAKAVAGE** Paper Size

DATE: **11-SEP-15** **A3**

*PLAYGROUND SUPERVISION REQUIRED

Simplicity

Design Number: IPL-1508A - Bill Of Material

Ref. No.	Part No.	Description	Quantity
Posts			
1	ZZCH0028	3.5in OD x 136in STEEL POST W/ RIVETED CAP	4
Decks & Kick Plates			
2	ZZCH0616	SQUARE COATED DECK ASSEMBLY	1
Slides			
3	ZZCH2667	STAINLESS STEEL LIGHTNING SLIDE (48in DECK)	1
4	ZZCH8070	SLIDING POLE (48in DECK)	1
Activity Panels			
5	ZZUN4299	STEERING WHEEL (CH/EX PIPE WALL MOUNT FOR 4in CENTERS)	1
Barriers			
6	ZZCH4095	CENTERLINE PIPE WALL BARRIER	1
Climbers			
7	ZZCH8290	RIBBON CLIMBER (48in DECK)	1
Additional Tool & Maintenance Kits			
8	ZZCHGUID	CHALLENGER GUIDELINES	1
9	ZZUN9910	SURFACING WARNING LABEL KIT	1
10	ZZUN9935	PIPE SYSTEMS MAINTENANCE KIT W/O AEROSOL	1
11	ZZXX0109	EN-1176 LABEL	1
12	ZZXX0158	EN & JPFA HOLE PLUG KIT FOR ECO-ARMOR (40 COUNT)	1

Simplicity

Design Number: IPL-1508A - Compliance and Technical Data

Reference Document: EN1176:2008

Ref. No.	Part No.	Qty.	Description	Unit EN Status	Total Weight (lbs)	Pre-Consumer Recycled Content (lbs)	Post-Consumer Content (lbs)	CO2e Footprint (kgs)	Users	Install Hours	Concrete (Yds3)	Active Play Events
1	ZZCH0028	4	3.5in OD x 136in STEEL POST W/ RIVETED CAP	Certified	174.04			234	0	4.00	0.50	0
2	ZZCH0616	1	SQUARE COATED DECK ASSEMBLY	Certified	54.86			174	3	1.00	0.00	0
3	ZZCH2667	1	STAINLESS STEEL LIGHTNING SLIDE (48in DECK)	Certified	124.34			2,445	2	1.50	0.06	1
4	ZZCH8070	1	SLIDING POLE (48in DECK)	Certified	56.43			156	1	1.50	0.03	1
5	ZZUN4299	1	STEERING WHEEL (CH/EX PIPE WALL MOUNT FOR 4in CENTERS)	Certified	5.29			27	1	0.25	0.00	1
6	ZZCH4095	1	CENTERLINE PIPE WALL BARRIER	Certified	28.74			71	0	0.50	0.00	0
7	ZZCH8290	1	RIBBON CLIMBER (48in DECK)	Certified	38.72			110	2	1.50	0.06	1
8	ZZCHGUID	1	CHALLENGER GUIDELINES	N/A	0.00			1	0	0.25	0.00	0
9	ZZUN9910	1	SURFACING WARNING LABEL KIT	N/A	0.05			1	0	0.25	0.00	0
10	ZZUN9935	1	PIPE SYSTEMS MAINTENANCE KIT W/O AEROSOL	N/A				57				
11	ZZXX0109	1	EN-1176 LABEL	Certified	0.01			0	0	0.50	0.00	0
12	ZZXX0158	1	EN & JPFA HOLE PLUG KIT FOR ECO-ARMOR (40 COUNT)	N/A	1.20			42	0	0.00	0.00	0
Totals:					483.68	86	188	3,317	9	11.25	0.65	4
					217.66 Kg	39 Kg	85 Kg	3 Metric Tons			0.49 m3	



Simplicity

Design Number: IPL-1508A - Compliance and Technical Data

Reference Document: EN1176:2008

Ref. No.	Part No.	Qty.	Description	Unit EN Status	Total Weight (lbs)	Pre-Consumer Recycled Content (lbs)	Post-Consumer Content (lbs)	CO2e Footprint (kgs)	Users	Install Hours	Concrete (Yds3)	Active Play Events
----------	----------	------	-------------	----------------	--------------------	-------------------------------------	-----------------------------	----------------------	-------	---------------	-----------------	--------------------

EN1176:2008

This custom structure, drawing number IPL-1508A, has been designed to meet the general safety requirements of EN1176:2008. These requirements have been established with the consideration of the risk factor on available data. The items listed as certified have been reviewed and approved by a third party certification service. In addition to the product listing the overall layout and design of this structure, as shown in the plan, was completed in accordance with the general safety requirements of EN1176:2008.

Installation Times

Installation times are based on one experienced installer. A crew of three experienced individuals can perform the installation within the given time, each member working 1/3 of the given hours. [E.g. Installation Time = 30 hours. For a crew of three, each member will work 10 hours on the installation for a total of 30 hours on the project.]

Carbon Footprint

The CO2e (carbon footprint given in Kilograms and Metric Tons) listed above is a measure of the environmental impact this play structure represents from harvesting raw materials to the time it leaves our shipping dock. Playworld Systems nurtures a total corporate culture that is focused on eliminating carbon producing processes and products, reducing our use of precious raw materials, reusing materials whenever possible and recycling materials at every opportunity. Playworld Systems elected to adopt the Publicly Available Specification; PAS 2050 as published by the British Standards Institute and sponsored by Defra and the Carbon Trust. The PAS 2050 has gained international acceptance as a specification that measures the greenhouse gas emissions in services and goods throughout their entire life cycle.

Pre-Consumer Recycle Content

A measurement, in pounds, that qualifies the amount of material that was captured as waste and diverted from landfill during an initial manufacturing process and is being redirected to a separate manufacturing process to become a different product. E.g. 100% of our Aluminum Tubing is made from captured waste material during the manufacturing process of extruded Aluminum products such as rods, flat bars and H-channels.

Post-Consumer Recycle Content

A measurement, in pounds, that qualifies the amount of material that was once another product that has completed its lifecycle and has been diverted from a landfill as a solid waste through recycling and is now being used in a Playworld Systems' product. E.g. **20% to 40% of the steel in our steel tubing and sheet steel have been diverted from landfills. Automobiles are scrapped and recyclable steel is purchased by the steel mill that produces our raw product.

** The amount of Post-Consumer recycled steel fluctuates daily based on the availability of the recycled steel.

